

Beaver Models Helium Car Instructions – O / P48 (Rev 11)

Thank you for buying this model of a GATX Helium Car. I hope you find these instructions helpful, and the kit is as good as or better than you expected. Please read all the instructions before starting. This kit would not be possible without fantastic support and reference material from Jay Miller. Also, for Pat Bray's review of the model and instructions. It was Pat's article on how to update an AHM HO scale model that inspired me to find a better way.

STEP 1:

The 3d printing process will leave some small marks and "tags" that might need to be cleaned up. Do not mistake rivets or alignment pins as "tags". You can test fit the parts, however, be careful as some of the parts are fragile and can break.

If any of the parts warp, a quick dunk, no more than in-and-out (1/2 second?), in Isopropyl Alcohol, might do the trick. I use 99% IPA to clean resin residue off parts after they've drained following printing but 91%, maybe 70%, should work. The key is to NOT let them soak, just hold with tweezers and "do the dunk". Let them dry overnight on a flat surface with a paper towel and they should regain the flexibility.

Note where the small holes for the grab irons are located. The hardest ones to see are the low hanging steps on the bottom side edges of the frame near both ends and are angled at 20 degrees from vertical.

The tanks will fit into both ends of the car but might require a little squeeze and wiggling on the sides to align all 30 tanks into the alignment holes. The blocks between all the tanks will be on the bottom.

I have only used ACC glue, so I do not know how well others work.

STEP 2:

Decide on what era you want your car to represent. This will decide the look of the car such as, color (Battleship Gray or Aluminum), markings, length of ladders, and the existence of the roof walk. If you need to remove the roof walk or shorten the ladders, the alignment holes on the car need to be filled prior to painting and assembly. This model is based upon drawings of the Third Generation "Navy" car built by GATC numbered 1013 – 1078 from November 1942 to August 1943. This became the basic design. Others that followed were similar with only minor changes.

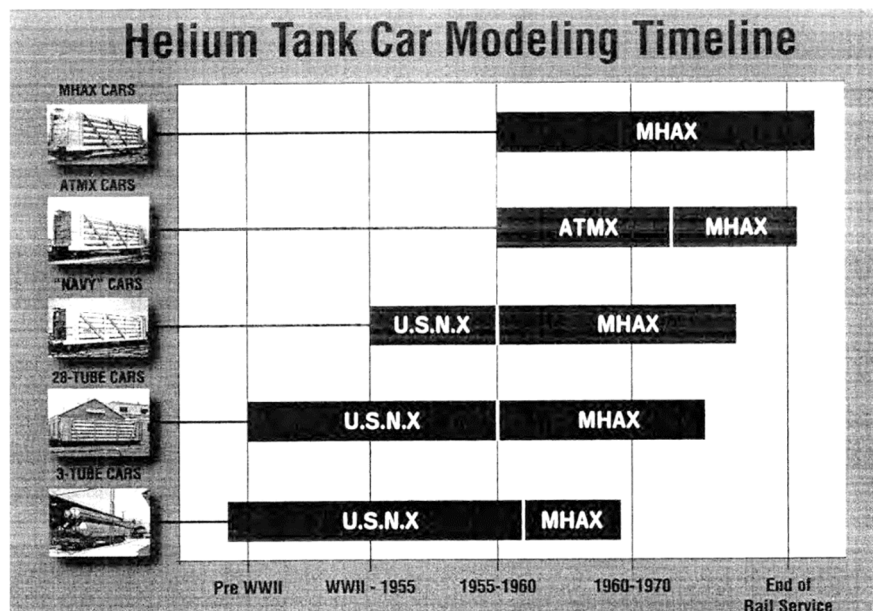

Quick Roster of Helium Tank Cars

Reporting Marks	Car Numbers	Builder	Date	Comments
Early 3-Tube Cars				
USQX	101-102	Bethlehem	1926-1927	Built for US Army Air Service
USNX	1001	Bethlehem	1926	Built for US Navy
First Generation: 28-Tube Cars				
USNX	1002-1006	GATC	1930	Rebuilt with 'X' brace, ca. 1940
Second Generation: 30-Tube Cars				
USNX	1007-1012	GATC	1933	Rebuilt with 'X' brace, ca. 1940
Third Generation: 30-Tube Cars				
USNX	1013-1078	GATC	1942-1943	Painted all Battleship Gray w/black U/F and hardware. Seven cars relettered for ATMX in 1955.
Fourth Generation: 30-Tube Cars				
MHAX	1079-1138	ACF	1955-1959	First use of MHAX reporting marks in July 1955. Cars 1119 and later (1959 built) in this generation built with roller bearing trucks and metal roof walks. Painted gray with aluminum tanks.
Fourth Generation: 30-Tube Cars				
ATMX	1001-1005	ACF	1955	First cars lettered ATMX. Ditto above.
ATMX	1013-1019	ACF	1955	
ATMX	1020-1025	Darby Corp.	1958	
Fifth Generation: 30-Tube Cars				
MHAX	1139-1163	ACF	1960	Roller bearing trucks, metal roof walks.
Sixth Generation: 30-Tube Cars				
MHAX	1164-1173	Magor	1961	Roller bearing trucks, metal roof walks.
Seventh Generation: 30-Tube Cars				
MHAX	1174-1196	ACF	1961	Roller bearing trucks, metal roof walks.
Eighth Generation: 30-Tube Cars				
MHAX	1197-1221	Magor	1962	Metal roof walks, roller bearing trucks without clasp brakes. All cars painted aluminum except trucks and H/W.

Total Cars Built: 241

When built, all cars equipped with solid bearing, clasp brake trucks except as noted.

Changeover from USNX to MHAX/ATMX reporting marks occurred in June-July 1955.

Changeover from gray superstructure and aluminum painted tanks to all aluminum paint begun after 1962.

All cars in active fleet were relettered to MHAX after ca. 1964.

Extensive rebuilding began ca. 1970 with removal of roof walks, new trucks, etc.

All cars retired or disposed of by 1998.

Decide if you are going to use the included solid bearing trucks with frame mounted couplers or, trucks with couplers mounted, not provided.

See the following excellent website for research materials.

<https://www.amarillorailmuseum.com/helium-car-history>

Possible car configurations as I see them (see page 9 for paint suggestions):

1942-1955 USNX: Battleship Gray all over with black trucks, ladders, steps, and grab irons. Roof walks appear as treated wood. Note: All cars converted from USNX to MHAX or 7 for ATMX in June-July 1955.

1955-1964 MHAX or ATMX: Battleship Gray all over except with Aluminum painted tanks. Black trucks, ladders, steps, and grab irons. Roof walks appear as treated wood. Roller bearing trucks did not start showing up until after 1955 on cars 1119 and later. Note: all cars were MHAX by 1964.

1964-1972 MHAX: Aluminum painted all over. Roof walks appear as treated wood. Black trucks, ladders, steps, and grab irons.

1972-1998

MHAX: Aluminum painted all over. Black trucks, ladders, steps, and grab irons. No roof walk, shortened side and non-brake end ladders (match side length) (fill in holes). Brake end ladder and brake wheel location did not change.

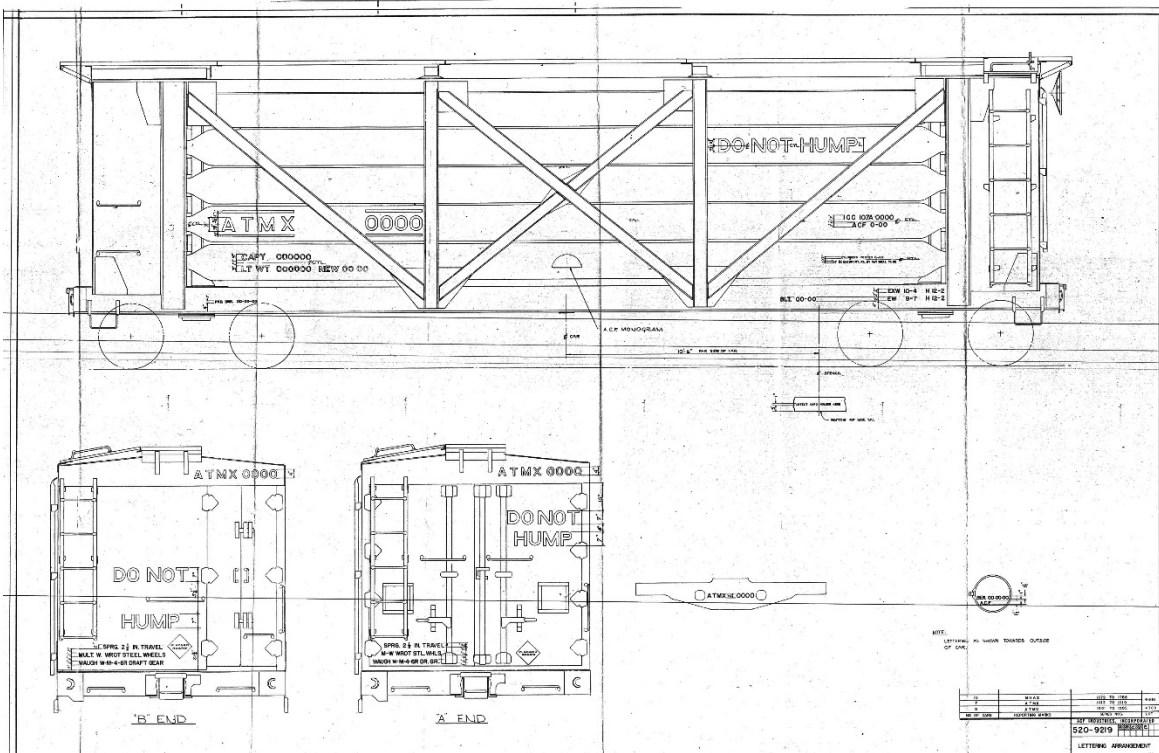
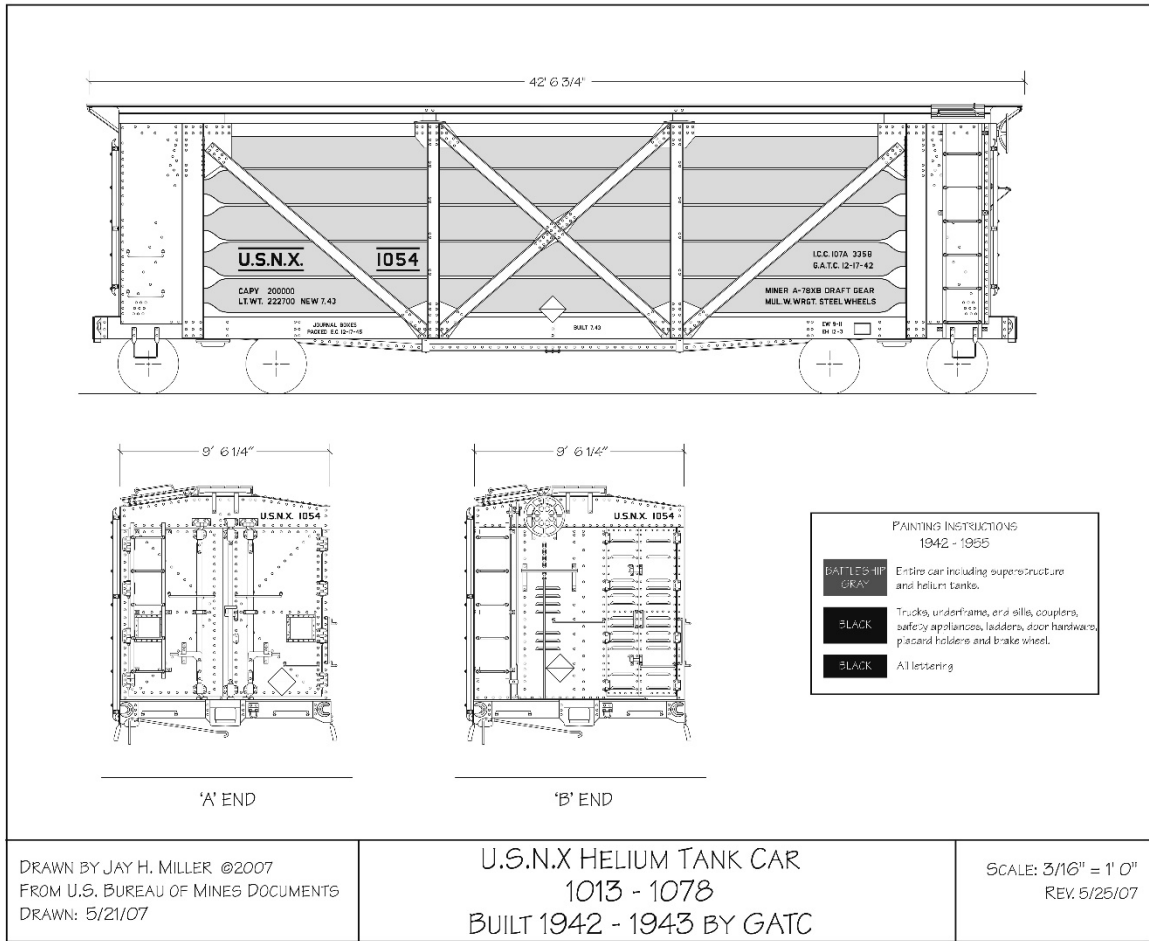

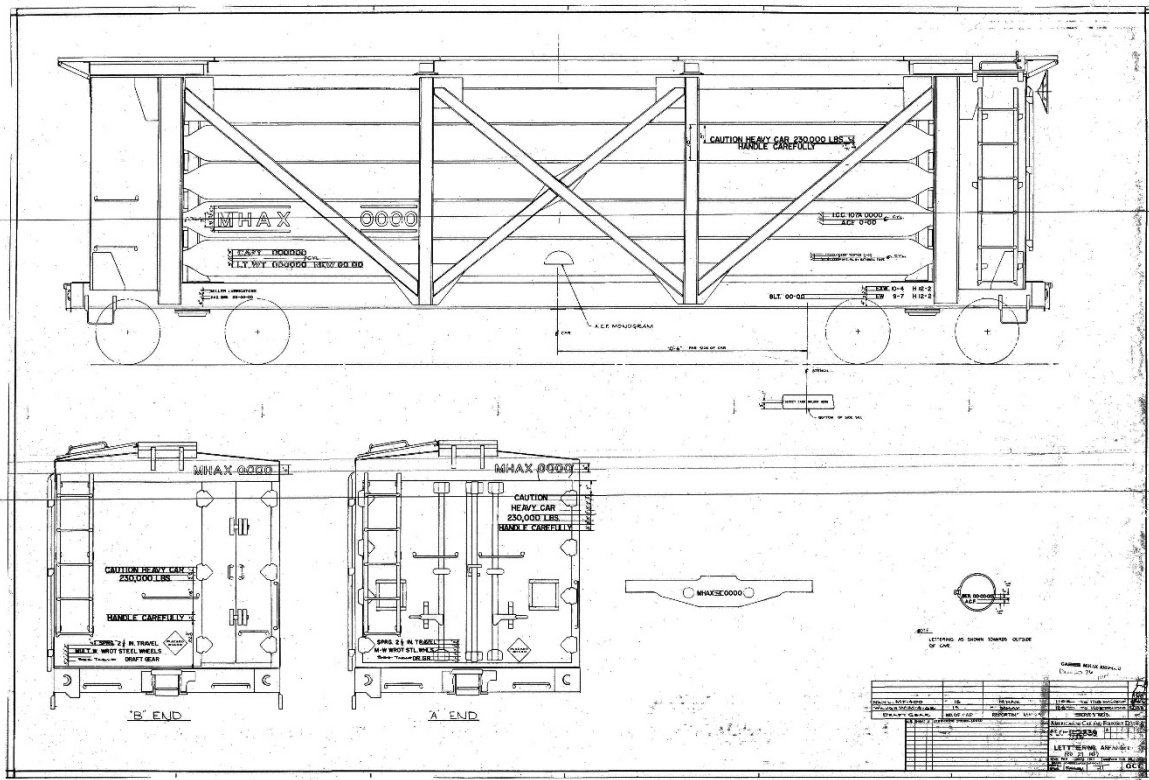

K4 Decal Instructions:

As built these cars were battleship gray with silver tanks. Starting in the 1960s, these cars were repainted entirely silver. Also, at that time, the lines above and below the numbers and reporting marks were omitted.

For best results, apply decals to a painted surface. They will not bond to most unpainted plastics. Cut desired decal from the sheet with sharp scissors. Soak the cut decal in clean, warm water for 20 seconds. Remove the decal from water before the backing comes off. Slide the decal from the paper onto the desired surface. Blot excess water from the edges of the decal. Allow to dry. On rough or uneven surfaces, apply a decal setting solution such as Microscale Micro-Set to help the decal settle onto the surface. Apply a clearcoat once the decals are fully dry and set.

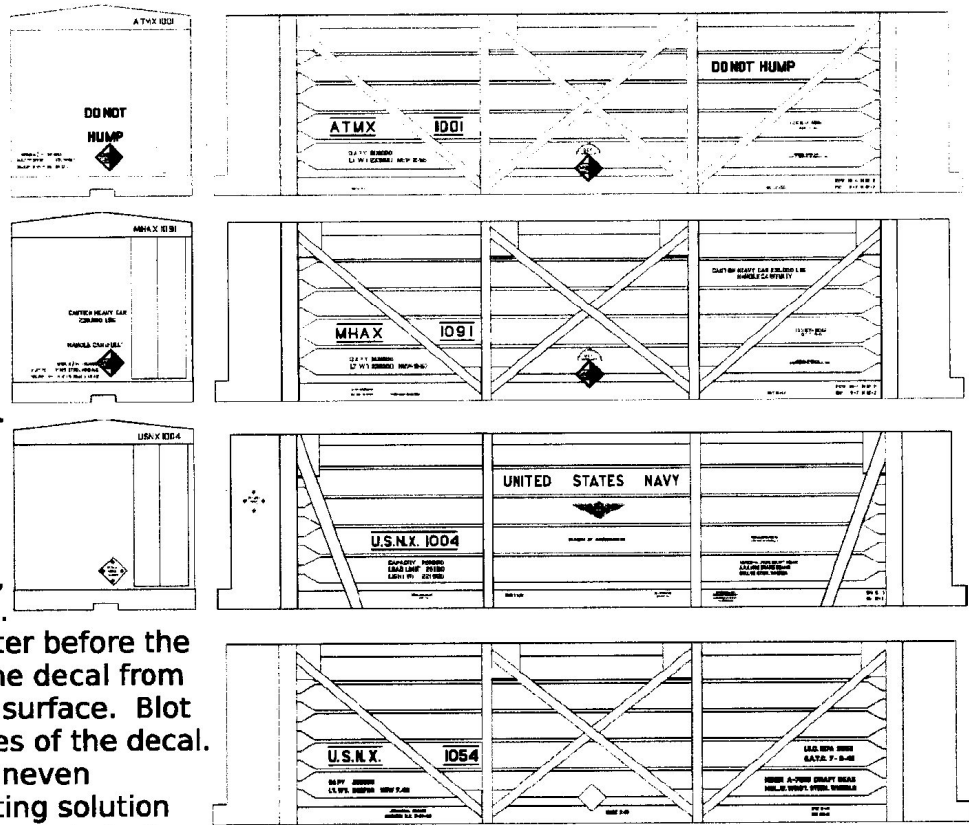

MHAX, ATMX, Navy Helium Tank Cars K4-MHAX-87 B



STEP 3:

Paint the model parts prior to assembly as some areas would be impossible to paint after assembly. As a suggestion, wash the parts with Dawn dish soap prior to painting. I recommend adding the grab irons prior to painting.

STEP 4:

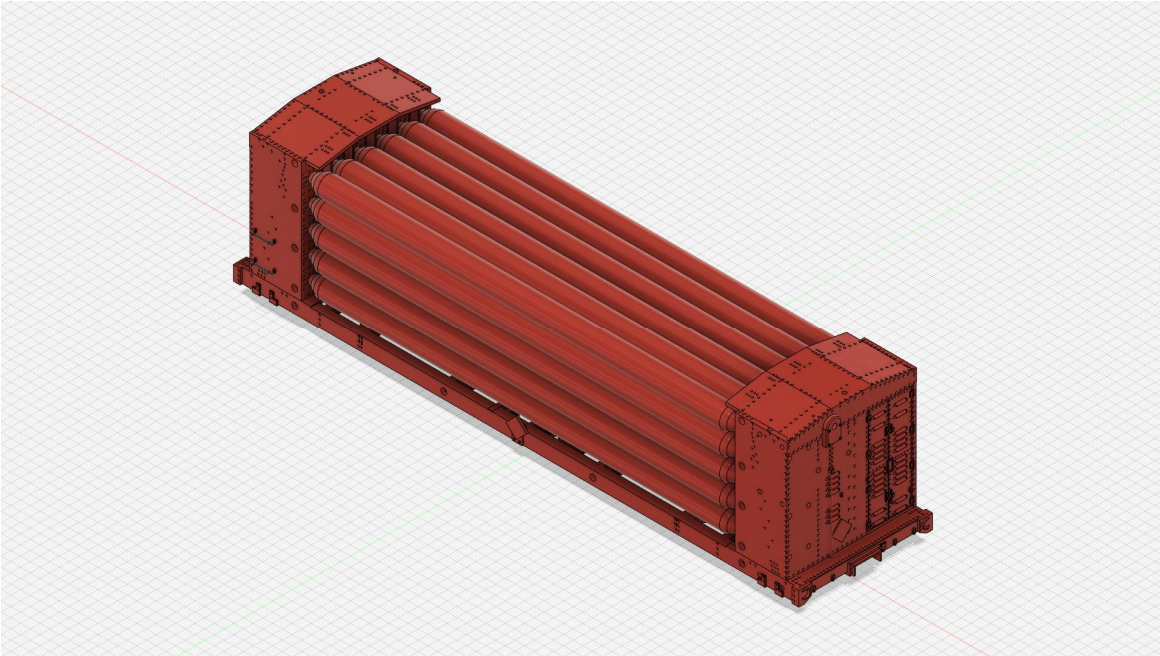

Once the paint is dry and the decals are set, without using glue, attach both car ends to the tanks with the blocks on the tanks to the bottom. Some slight pressure and wiggling on the sides of the tanks help align the holes. **DO NOT GLUE THE TANKS TO THE ENDS.** This will allow some adjustment to align all the other parts. The bottom and side frames will hold the model together. No extra weight needed. Now glue the frame and the sides shown below (sides are identical). Carefully align the car ends onto the frame so that there is no overhang of the sides.

STEP 5:

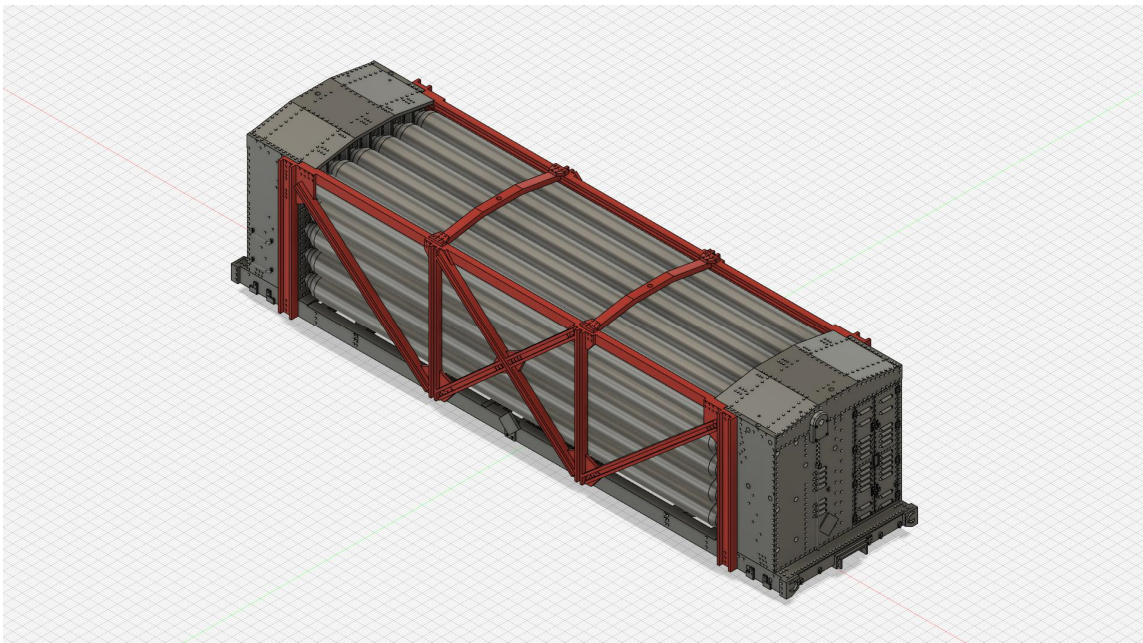

Next, glue the top frames.

STEP 6:

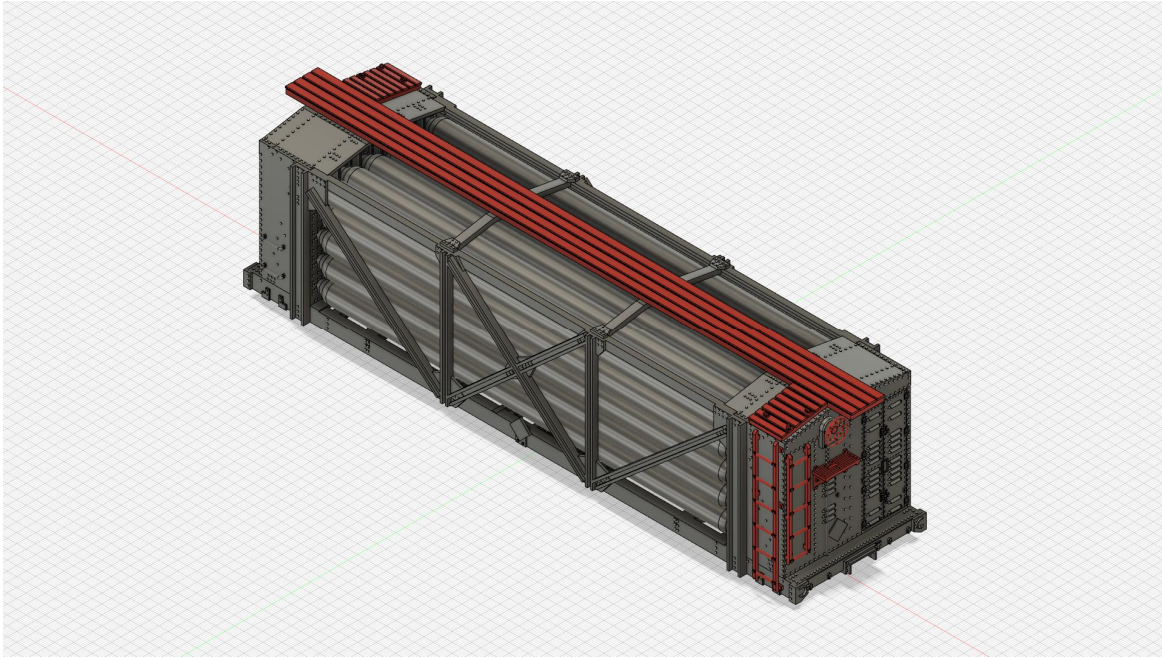

Next, attach the roof walk and all 4 ladders (see notes). Attach the brake stand and brake wheel.

Note: The side ladder bottom alignment holes, into the frame, share some space with the 18" grab irons/step holes on the bottom edge of the frame. So do not glue the bottom of the side ladders until the grab irons/steps are in place. You can glue both from the bottom.

Note: Latter cars (post 1970) require the side ladders to be shortened by cutting off the top two steps just above the middle attachment points and not installing the roof walk which were no longer allowed. Also shorten the non-brake end ladder to match the side ladder. Fill unused attachment holes.

For ease, you can now finish any of the decals prior to installing the grab irons.

Note: The end of car decals might become "interesting" to have them mold on top of the vents and rivets. There are products you can use to soften the decal to form around these but be careful as it dissolves the decal film.

STEP 7:

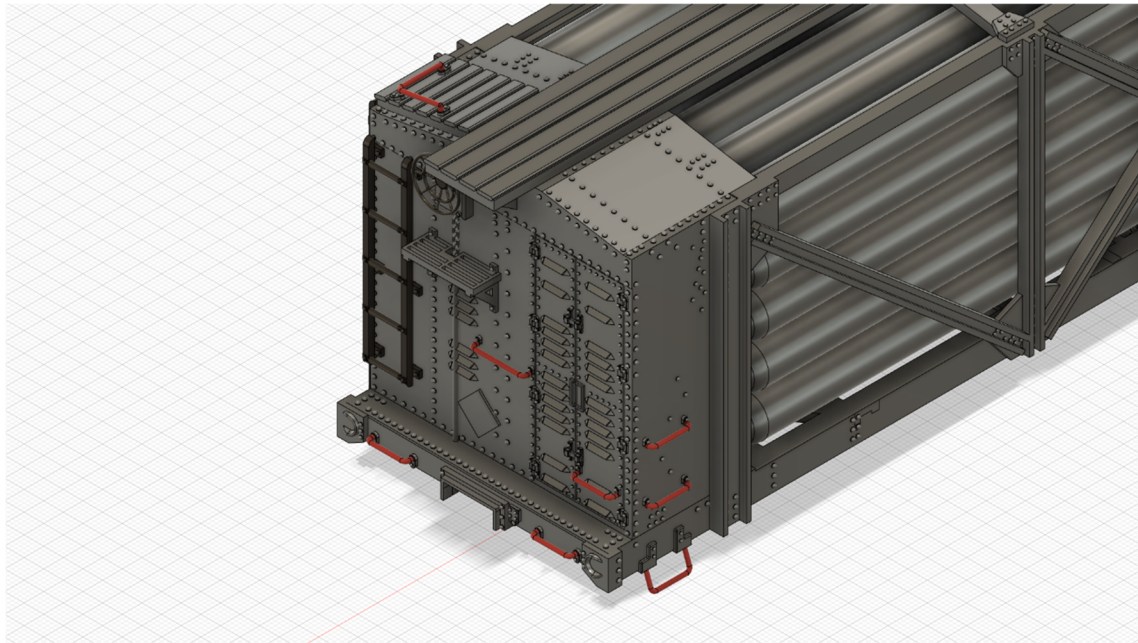
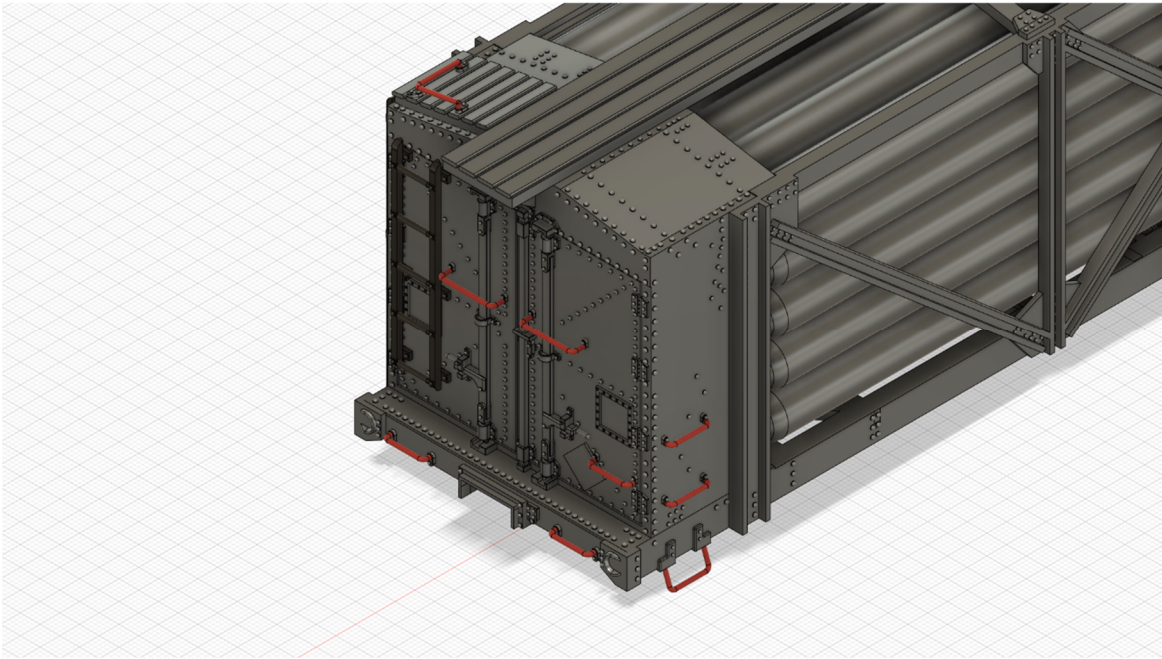

Next, attach grab irons, if not already installed prior to painting. These can be trimmed, as needed. A #80 or #79 drill might be needed to clean out the holes.

- There are four 18" grab irons/steps on the bottom edge of the frame that stick out (about 1/8") at a 20-degrees off vertical. They share some space with the bottom side ladder alignment pins (See Note on previous page).
- There are two 18" grab irons on each end of the frame for a total of four.
- There is one 18" and two 24" grab irons on Car End A (non-brake wheel) end.
- There is one 18" and one 24" grab iron on Car End B (brake wheel) end.
- There are two 18" grab irons on both car ends on the sides opposite the side ladders.
- Finally, there are two angled grab irons, one on each corner, of the roof walk.

STEP 8:

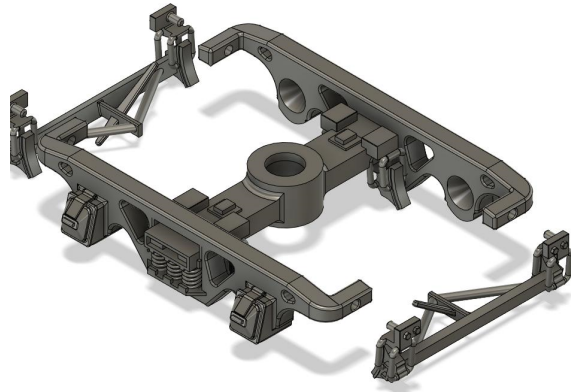

Install the wheel sets into the trucks by gently spreading the sides of the truck. Then attach the brake ends to the truck. They might have a tight fit that will require a little bit of careful force. I recommend only gluing one side of the brake end to allow spreading the truck to paint or replace the wheels later. Fill in attachment holes if the brake ends are not used.

STEP 9:

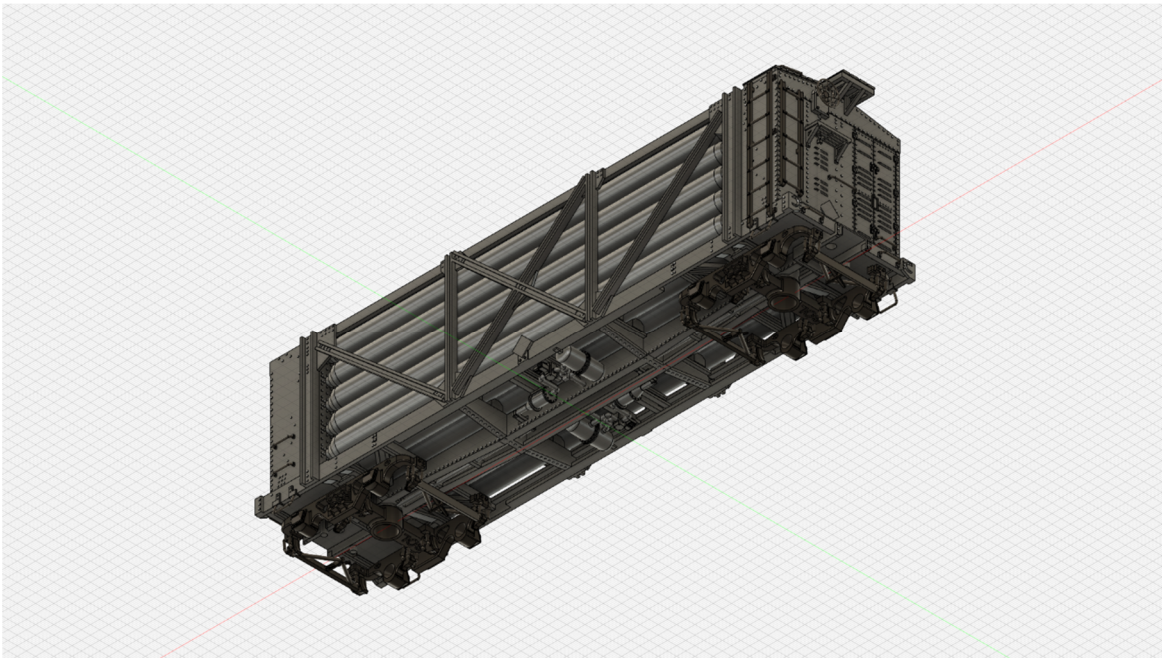

If using the included trucks, instead of trucks with couplers mounted, assemble and glue a set of KaDee couplers onto the frame.

Wheels and couplers are not depicted in the drawings.

If you do use your own trucks with couplers mounted, check for clearance.

Then attach the trucks with the silver screws.

The weight of the car is heavy and so no extra weight should be needed.

Some Final Comments:

If for some reason a part breaks that you cannot easily fix, email me and I will replace it. I just ask you to pay a nominal \$5.00 to help cover postage. I will not charge you if the part shows up broken or missing from the kit. The exception is the alignment pins on the ends on the tanks sometimes break, but they are hidden when the model is put together and there are 30 of them on each end. So, a few missing will not hurt the structure of the model.

If you use a currently available paint for Battleship Gray or Aluminum, please let me know so I can share it. Most Battleship Grays appear to be too dark and so consider a lighter shade of gray.

If you do publish a review on this kit, I would appreciate a courtesy copy so I can get an idea on how the kit is received. I hope it is positive but would like to know anything negative about the kit. This is my first 3D project and I want to know your comments.

One last thing, when you build the kit, I would like to get a photo emailed to me of your model. I might include some in future advertising.

Again, I would like to hear from you on your opinion of the kit. Just drop me an email or leave feedback if you bought it on eBay.

Greg Brubaker

BeaverModels@aeroimage.com

If you want more kits or know of someone who might want one go to:

<https://beavermodels.com/>

This way you save on some fees, if you purchased on eBay.

Customer Paint Comments:

J.D. 1

"The paint has been a bit of a headache for painting early cars, which is what I am modeling (late 1950's). Most photos of these cars are black and white, which makes it difficult to figure out which shade of gray, and the few color photos I've found aren't much help, either. Then there's the "miniaturization effect" which also makes the paint appear darker. I painted my first car Tamiya light battleship gray, which is too dark. My second car is being lettered ATMX. For the gray on this one I chose Tamiya Medium Sea Gray (AS-32) and am happy with that. I also looked at Tamiya USAF Neutral Gray (AS-7) and USAF Light Gray (AS-16) when selecting the gray color. All three are very close in shade of gray."

J.D. 2

"The first car is a USNX car which I painted Tamiya Battleship grey, which is way too dark. The second car is an ATMX car that I painted Tamiya Ocean Gray and Silver Leaf. The gray is very close to the gray in the few color photos there are of this car."

Myself

I use Rust-Oleum Flat Protective Enamel in both Smoke Gray and Black. The paint worked great for me and is close to the color of gray I wanted. It also works great out of the can or carefully drained to use in an air-brush. Others used Rust-Oleum 2X Winter Gray.

Parts Inventory - O:

Name	Qty	Location	Checked
Car End A (non-brake wheel)	1	Wrapped	
Car End B (brake wheel)	1	Wrapped	
Frame	1	Wrapped	
Tanks	1	Wrapped	
Side Frames	2	Wrapped	
Roof Walk	1	Wrapped	
Top Frames	2	SmBag1	
Brake Stand	1	SmBag1	
Brake Wheel	1	SmBag1	
Side Long Ladders	2	SmBag1	
End Short Ladders	2	SmBag1	
Silver 4-40 x 3/8 Screws	2	SmBag1	
KaDee #805 Couplers	1	Packet	
Corner Grab Irons	2	SmBag2	
18" Grab Irons	14+	SmBag2	
24" Grab Irons	3	SmBag2	
Solid Bearing Trucks	2	LgBag1	
Truck Brake Ends	4	LgBag1	
Intermountain 33" Wheels	4	LgBag2	
Decal Sheet	1	In Box	
Printed Instructions	1	In Box	
Invoice Sheet	1	In Box	
Business Cards	3+	In Box	

Request for Information:

In my research, I have heard about some of these cars painted with US Air Force and NASA markings. I have found a couple of photos of Air Force cars being scrapped, but do not have any information on how many or when these were done. If you find any photos of these or information, I would greatly appreciate an email.

Also, any photos of the cars on Navy bases in WWII. Ideally, with a blimp/blimp hanger in the photo.

Basically, any photos of these cars when they were still operational. If the photo is not already available via:

<https://www.amarillorailmuseum.com/helium-car-history>